



## Product Specification

Model : **P070WQ0-A00**

Tentative Specification

Final Specification

Customer :	
Approve By :	
Date :	
Note :	

Note: This Specification is subject to change without notice.

Prepared by :	
Approve By :	
<b>Multi Electron Optronics Co., Ltd</b>	



## Record of Revisions

<b>Ver.</b>	<b>Date</b>	<b>Page</b>	<b>Description of change</b>
1.0	Jun.22.2006	All	Product specification was first issued.



## Contents

1.0	General description .....	p.4
2.0	Absolute maximum ratings .....	p.5
3.0	Optical characteristics .....	p.6
4.0	Block diagram .....	p.10
5.0	Interface pin connection .....	p.11
6.0	Electrical characteristics .....	p.12
7.0	Outline dimension .....	p.19
8.0	General precaution .....	p.20



## 1.0 GENERAL DESCRIPTION

### 1.1 Introduction

**P070WQ0-A00** is a color active matrix thin film transistor (TFT) liquid crystal display (LCD) that uses amorphous silicon TFT as a switching device. This model is composed of a TFT LCD panel, a driving circuit and a back light system. This TFT LCD has a 7.0 (16:9) inch diagonally measured active display area with 1440 x 234 dot (480 horizontal by 234 vertical pixels) resolution.

### 1.2 Features

- 7 (16:9 diagonal) inch configuration
- Compatible with NTSC & PAL system
- Image Reversion: UP/DOWN and LEFT/RIGHT

### 1.3 Applications

- Portable TV
- Portable DVD
- Multimedia applications and Others AV system

### 1.4 General information

Item		Specification	Unit
Outline Dimension		164.9 x 100 x 5.5 (Typ.)	mm
Display area		154.08(H) x 86.58(V)	mm
Number of Pixel		480 RGB(H) x234(V)	pixels
Pixel pitch		0.321(H) x 0.370(V)	mm
Pixel arrangement		RGB Vertical stripe	
Display mode		Normally white	
Surface treatment		Antiglare, Hard-Coating(3H) with WV film	
Weight		(165)	g
Back-light		Single CCFL (Side-Light type)	
Power Consumption	Logic System	(36.4)	mW
	B/L System	(3.3)	W

### 1.5 Mechanical Information

Item		Min.	Typ.	Max.	Unit
Module Size	Horizontal(H)	164.4	164.9	165.4	mm
	Vertical(V)	99.5	100.0	100.5	mm
	Depth(D)	—	(5.5)	—	mm
Weight (Without inverter)		—	(165)	—	g

## 2.0 ABSOLUTE MAXIMUM RATINGS

### 2.1 Electrical Absolute Rating

#### 2.1.1 TFT LCD Module

Item	Symbol	Min.	Max.	Unit	Note
Power supply voltage	DV <sub>DD</sub>	-0.3	6.0	V	GND=0
	V <sub>GH</sub>	-0.3	40	V	GND=0
	V <sub>GL</sub>	-20	0.3	V	GND=0
	V <sub>GH</sub> - V <sub>GL</sub>	-0.3	40	V	
	AV <sub>DD</sub>	-0.3	7.0	V	AGND=0
	V <sub>COM</sub>	-1.6	5.2	V	
Analog Signal Input Level	V <sub>R</sub> , V <sub>G</sub> , V <sub>B</sub>	-0.2	AV <sub>DD</sub> +0.2	V	
Logic Signal Input Level	V <sub>I</sub>	-0.3	DV <sub>DD</sub> +0.3	V	

#### 2.1.2 Back-Light Unit

Item	Symbol	Min.	Max.	Unit	Note
Lamp current	I <sub>L</sub>	0	7.0	mA	(1) (2)
Lamp frequency	f <sub>L</sub>	0	100	KHz	(1) (2)

Note (1) Permanent damage may occur to the LCD module if beyond this specification.  
 Functional operation should be restricted to the conditions described under normal operating conditions.

(2) Ta =25±2°C

### 2.2 Environment Absolute Rating

Item	Symbol	Min.	Max.	Unit	Note
Operating Temperature	T <sub>opa</sub>	-10	60	°C	
Storage Temperature	T <sub>stg</sub>	-20	70	°C	

### 3.0 OPTICAL CHARACTERISTICS

#### 3.1 Optical specification

Item		Symbol	Condition	Min.	Typ.	Max.	Unit	Note
Contrast		CR	Θ=0 Normal viewing angle	—	(350)	—		(1)(2)
Response time	Rising	T <sub>R</sub>		—	(5)	—	ms	(1)(3)
	Falling	T <sub>F</sub>		—	(20)	—		
White luminance (Center)		Y <sub>L</sub>		—	(280)	—	cd/m <sup>2</sup>	(1)(4) (I <sub>L</sub> =6.0mA)
Color chromaticity (CIE1931)	White	W <sub>x</sub>			(0.31)			(1)(4)
		W <sub>y</sub>		(0.33)				
Viewing angle	Hor.	Θ <sub>L</sub>	CR>10	—	60	—		
		Θ <sub>R</sub>		—	60	—		
	Ver.	Θ <sub>U</sub>		—	40	—		
		Θ <sub>D</sub>		—	60	—		
Brightness uniformity		B <sub>UNI</sub>	Θ=0	70	—	—	%	(5)

#### 3.2 Measuring Condition

- Measuring surrounding : dark room
- Lamp current I<sub>FL</sub> : 6.0±0.1mA(rms), Lamp freq. F<sub>L</sub>=50KHz
- Ambient temperature : 25±2°C
- 30min. warm-up time.

### 3.3 Measuring Equipment

- TOPCON BM-7 for Chromaticity and other optical characteristics.
- Measuring spot size : 10 ~ 12 mm

**Note (1)** Definition of Viewing Angle :

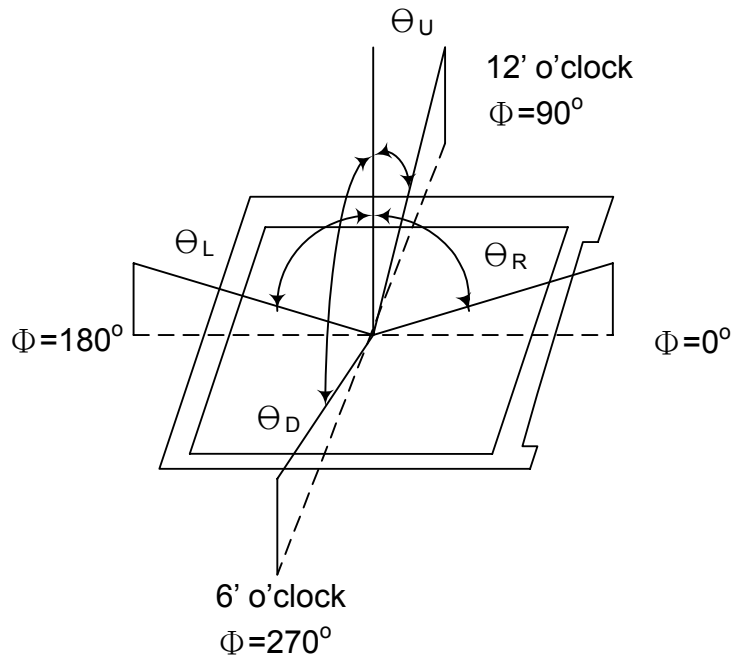

**Note (2)** Definition of Contrast Ratio(CR) :  
 measured at the center point of panel

$$CR = \frac{\text{Luminance with all pixels white}}{\text{Luminance with all pixels black}}$$

**Note (3)** Definition of Response Time : Sum of  $T_R$  and  $T_F$

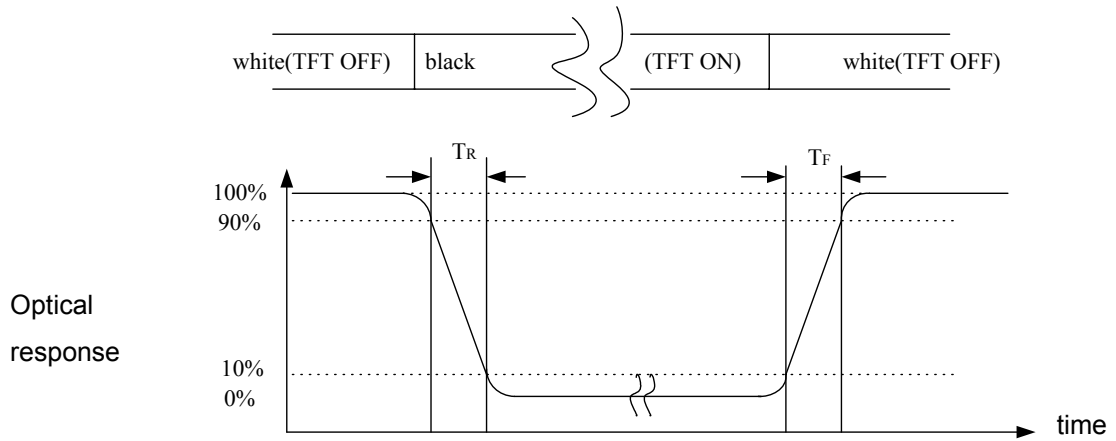

**Note (4)** Definition of optical measurement setup

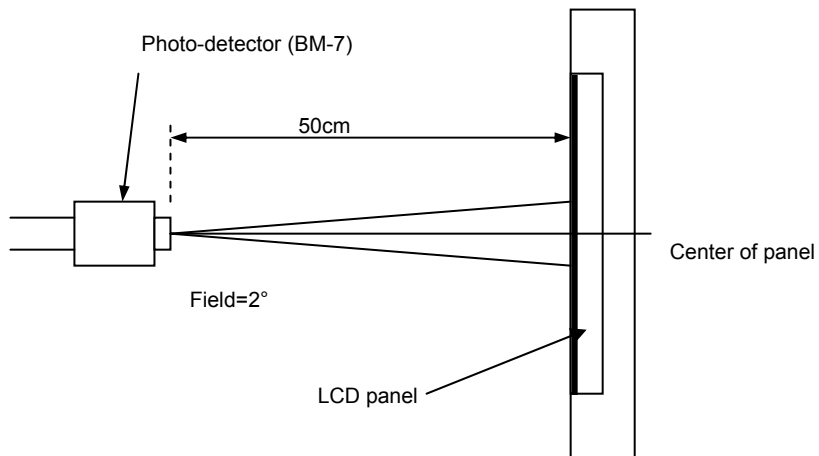



**Note (5)** Definition of brightness uniformity

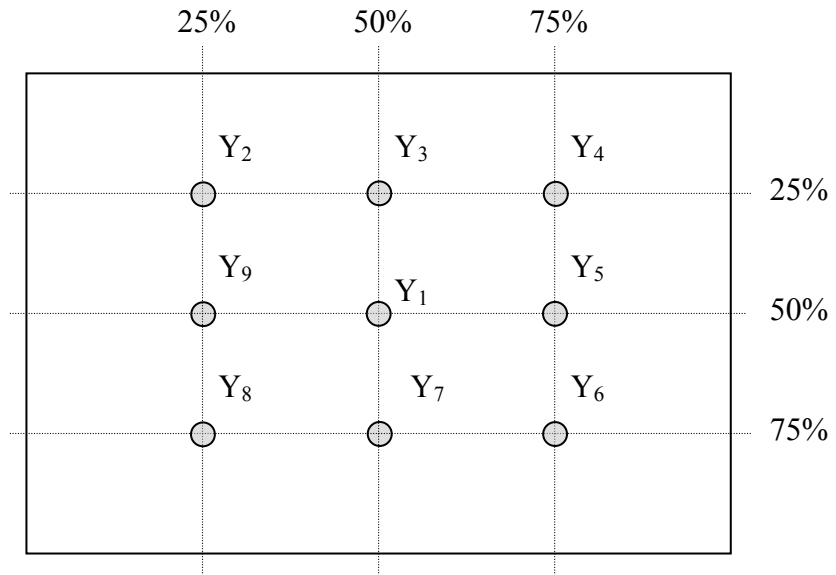

$$\text{Luminance uniformity} = \frac{(\text{Min Luminance of 9 points})}{(\text{Max Luminance of 9 points})} \times 100\%$$

## 4.0 BLOCK DIAGRAM

### 4.1 TFT LCD Module

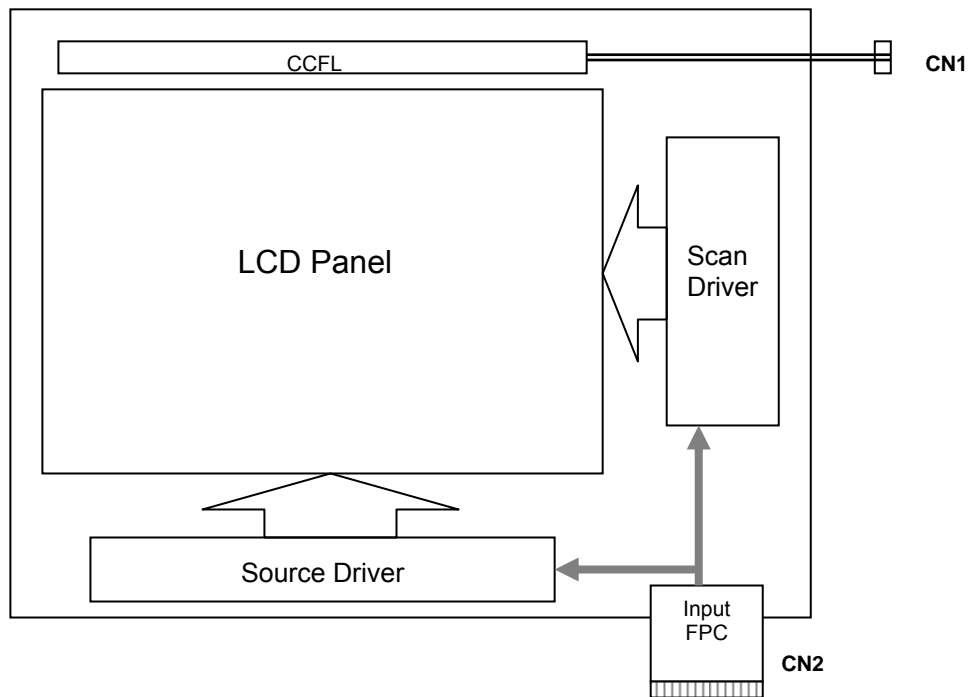

### 4.2 Pixel Format

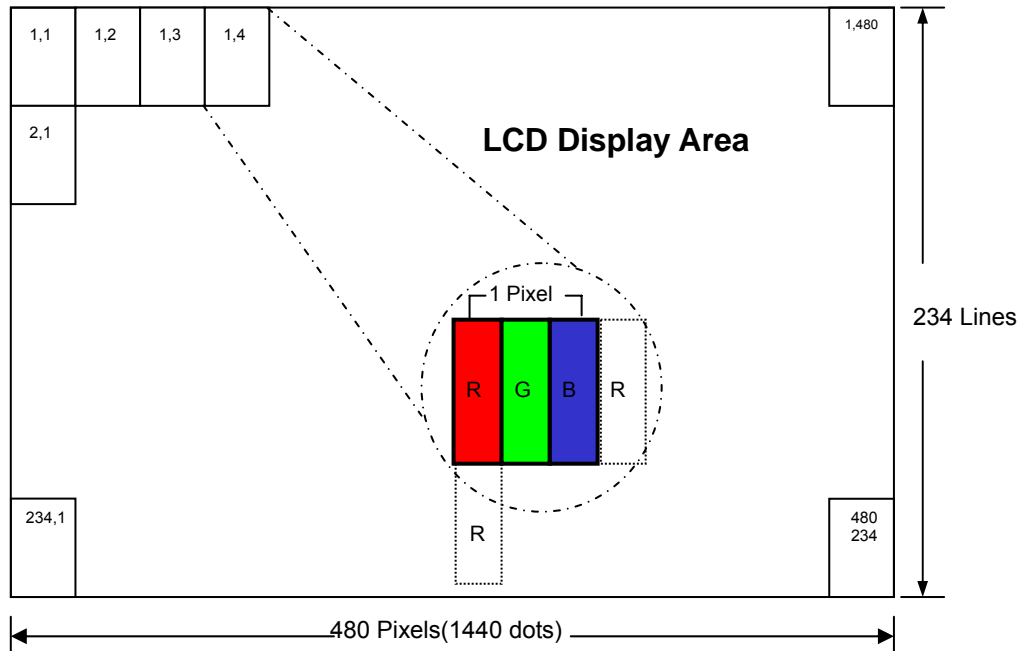

## 5.0 INTERFACE PIN CONNECTION

### 5.1 TFT LCD Module

**CN2** (Input signal): FPC Down Connector, 26 pins, pitch: 0.5mm

Terminal no.	Symbol	I/O	Function	Note
1	DGND	-	Ground for logic circuit	
2	DV <sub>DD</sub>	I	Supply voltage of logic control circuit for scan (Gate) driver	
3	V <sub>GL</sub>	I	Negative power for scan (Gate) driver	
4	V <sub>GH</sub>	I	Positive power for scan (Gate) driver	
5	STVD	I/O	Vertical start pulse	(1)
6	STVU	I/O	Vertical start pulse	(1)
7	CKV	I	Shift clock input for scan (Gate) driver	
8	U/D	I	UP/DOWN scan control input	(1)
9	OEV	I	Output enable input for scan(Gate) driver	
10	V <sub>COM</sub>	I	Common electrode driving signal	
11	V <sub>COM</sub>	I	Common electrode driving signal	
12	L/R	I	LEFT/RIGHT scan control input	(1)
13	MOD	I	Sequential sampling and simultaneous sampling setting	(2)
14	OEH	I	Output enable input for data (Source) driver	
15	STHL	I/O	Start pulse for horizontal scan (Gate) line	(1)
16	STHR	I/O	Start pulse for horizontal scan (Gate) line	(1)
17	CPH3	I	Sampling and shifting clock pulse for data (Source) driver	(2)
18	CPH2	I	Sampling and shifting clock pulse for data (Source) driver	(2)
19	CPH1	I	Sampling and shifting clock pulse for data (Source) driver	
20	DV <sub>DD</sub>	I	Supply voltage of logic control circuit for data(Source) driver	
21	DGND	-	Ground for logic circuit	
22	V <sub>R</sub>	I	Alternated video signal input(Red)	
23	V <sub>G</sub>	I	Alternated video signal input(Green)	
24	V <sub>B</sub>	I	Alternated video signal input(blue)	
25	AV <sub>DD</sub>	I	Supply voltage for analog circuit	
26	AGND	-	Ground for analog circuit	

Note (1) Selection of scanning mode (please refer to the following table)

Setting of scan control input		IN/OUT state for start pulse				Scanning direction
U/D	L/R	STVD	STVU	STHR	STHL	
GND	DV <sub>DD</sub>	Output	Input	Output	Input	up to down, and from left to right.
DV <sub>DD</sub>	GND	Input	Output	Input	Output	down to up, and from right to left.
GND	GND	Output	Input	Input	Output	up to down, and from right to left.
DV <sub>DD</sub>	DV <sub>DD</sub>	Input	Output	Output	Input	down to up, and from left to right.

Note (2) MOD=H: Simultaneous sampling.(Please check CPH2 and CPH3 to GND when MOD=H)  
 MOD=L : Sequential sampling.

### 5.2 Back-Light Unit

**CN1** CCFL Power Source (**BHSR-02VS-1**) / JAPAN SOLDERLESS TERMINAL MFG CO., LTD.

Mating Connector: (**SBHT-002T-P0.5**) / JAPAN SOLDERLESS TERMINAL MFG CO., LTD.

Terminal no.	Symbol	Function
1	VL	CCFL power supply (high voltage)
2	GL	CCFL power supply (low voltage)

## 6.0 ELECTRICAL CHARACTERISTICS

### 6.1 TFT LCD Module

Item	Symbol	Min.	Typ.	Max.	Unit	Note
Supply Voltage	$DV_{DD}$	3	3.3	5.5	V	
	$V_{GH}$	14.3	15	15.7	V	
	$V_{GL}$	-10.5	-10	-9.5	V	
	$AV_{DD}$	4.5	5	5.5	V	
Video signal amplitude (VR, VG, VB)	$V_{iA}$	0.4	-	$AV_{DD}-0.4$	V	
	$V_{iAC}$	-	3	-	V	AC component,
	$V_{iDC}$	-	$AV_{DD}/2$	-	V	DC component
VCOM	$V_{CAC}$	-	5.6	-	VP-P	AC component
	$V_{CDC}$	1.6	1.8	2.0	V	DC component, (1)
Input signal voltage	$V_{iH}$	$0.8DV_{DD}$	-	$DV_{DD}$	V	(2)
	$V_{iL}$	0	-	$0.2 DV_{DD}$	V	(2)
Current of power supply	$I_{DD}$	-	127	-	uA	$DV_{DD} = 3.3V$
	$I_{ADD}$	-	7.0	-	mA	$AV_{DD} = 5V(\text{Black})$
	$I_{GH}$	-	70	-	uA	$V_{GH} = 15V$
	$I_{GL}$	-	65	-	uA	$V_{GL} = -10V$

Note (1): The brightness of LCD panel could be changed by adjusting the AC component of VCOM.

Note (2): STHL, STHR, OEH, L/R, CPH1~CPH3, STVD, STVU, OEV, CKV, U/D

Note (3): Be sure to apply the power voltage as the power sequence spec.

Note (4) : DGND=AGND=0V,)

## 6.2 Back-Light Unit

The back-light system is an edge-lighting type with 1 CCFL(Cold Cathode Fluorescent Lamp). The characteristics of the lamp is shown in the following tables.

Item	Symbol	Min.	Typ.	Max.	Unit	Note
Lamp current	IL	—	6.0	—	mA(rms)	(1)(6)
Lamp voltage	VL	—	548	—	V(rms)	(6)IL=6.0mA
Frequency	fL	—	50	—	KHz	(2)
Operating lamp life time	Hr	50,000	—	—	Hour	(3)
Startup voltage	Vs	1005	—	—	V(rms)	(4)(5)at 25°C
		1330				(4)(5)at 0°C

Note (1) Lamp current is measured with current meter for high frequency as shown below. Specified valued are for single lamp.

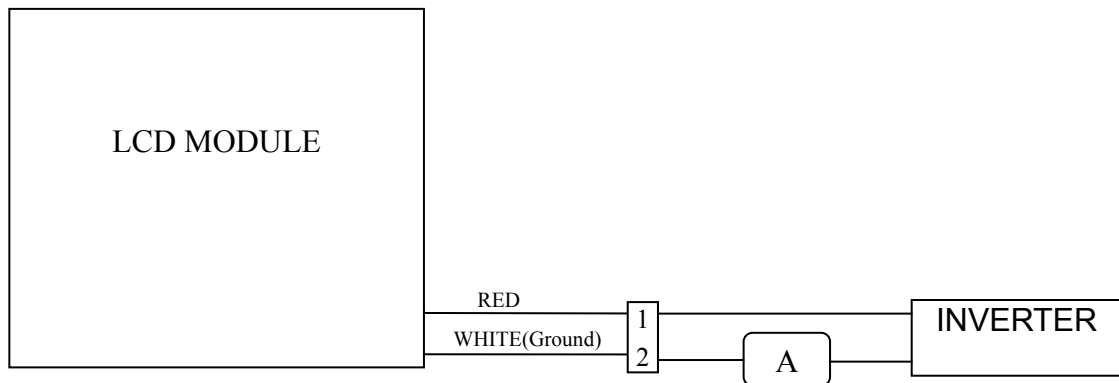

Note (2) Lamp frequency may produce interference with horizontal synchronous frequency and this may cause ripple noise on the display. Therefore lamp frequency shall be kept away from the horizontal synchronous frequency and its harmonics as far as possible in order to avoid interference.

Note (3) Lamp life time (Hr) can be defined as the time in which it continues to operate under the condition : Ta=25±3 °C, typical IL value indicated in the above table and fL=50kHz until the brightness becomes less than 50%.

Note (4) CCFL inverter should be able to provide a voltage over specified value (Vs) in the above table. Lamp units need at least Vs value shown above to ignition.

Note (5) The voltage over specified value (Vs) should be applied to the lamp more than 1 second after startup. Otherwise, the lamp may not be turned on. The used lamp current is the lamp typical current.

- Note (6) The output voltage waveform and current waveform of the inverter must be symmetrical (Unsymmetrical ratio is less than 10%). Please do not use the inverter which has unsymmetrical voltage and current waveform, and spike waveform. The inverter design which can provide the best optical performance, power efficiency, and lamp life should under the following conditions.
- The asymmetry rate of the inverter waveform should be less than 10%.
  - The distortion rate of the waveform should be within  $\sqrt{2}\pm 10\%$ .
  - The inverter output waveform should be better similar to the ideal sine wave.

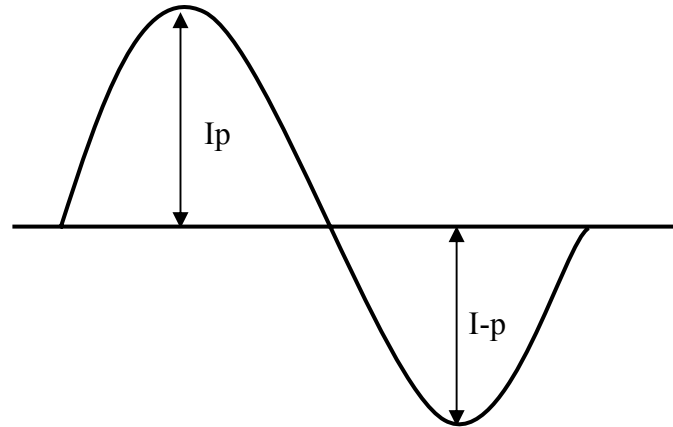

$$\text{Asymmetry rate} = |I_p - I-p| / I_{rms} \times 100\%$$

$$\text{Distortion rate} = I_p \text{ (or } I-p) / I_{rms}$$

### 6.3 AC Characteristics

Item	Symbol	Min.	Typ.	Max.	Unit	Note
Rising time	t <sub>r</sub>	-	-	10	ns	(1)
Falling time	t <sub>f</sub>	-	-	10	ns	(1)
High and low level pulse duty	t <sub>CPH</sub>	100	103	-	ns	CPH1~CPH3
CPH pulse duty	t <sub>CWH</sub>	40	50	60		CPH1~CPH3
STH setup time	t <sub>SUH</sub>	20	-	-	ns	STHR,STHL
STH hold time	t <sub>HDH</sub>	10	-	-	ns	STHR,STHL
STH pulse width	t <sub>STH</sub>	-	1	-	t <sub>CPH</sub>	STHR,STHL
STH period	t <sub>H</sub>	61.5	63.5	65.5	μs	STHR,STHL
OEH pulse width	t <sub>OEH</sub>	-	1.23	-	μs	OEH
Sample and hold disable time	t <sub>DIS1</sub>	-	8.19	-	μs	
OEV pulse width	t <sub>OEV</sub>	-	4.77	-	μs	OEV
CKV pulse width	t <sub>CKV</sub>	-	3.91	-	μs	CKV
Clean enable time	t <sub>DIS2</sub>	-	3.90	-	μs	
Horizontal display timing range	t <sub>DH</sub>	-	1440	-	t <sub>CPH</sub> /3	
STV setup time	t <sub>SUV</sub>	200	-	-	ns	STVD,STVU
STV hold time	t <sub>HDV</sub>	300	-	-	ns	STVD,STVU
STV pulse width	t <sub>STV</sub>	-	1	-	t <sub>H</sub>	STVD,STVU
Horizontal line per field	t <sub>V</sub>	256	262	268	t <sub>H</sub>	(2)
Vertical display start	t <sub>SV</sub>		3	-	t <sub>H</sub>	
Vertical display timing range	t <sub>DV</sub>		234	-	t <sub>H</sub>	
VCOM Rising time	t <sub>COM</sub>		-	5	μs	
VCOM Falling time	t <sub>COM</sub>		-	5	μs	
VCOM delay time	t <sub>COM</sub>		-	3	μs	
RGB delay time	t <sub>DRGB</sub>		*	1	μs	

Note (1): For all of the logic signals.

Note (2): Please don't use odd horizontal lines to drive LCD panel for both odd and even filed simultaneously.

### 6.4 Timing Diagram of Interface Signal

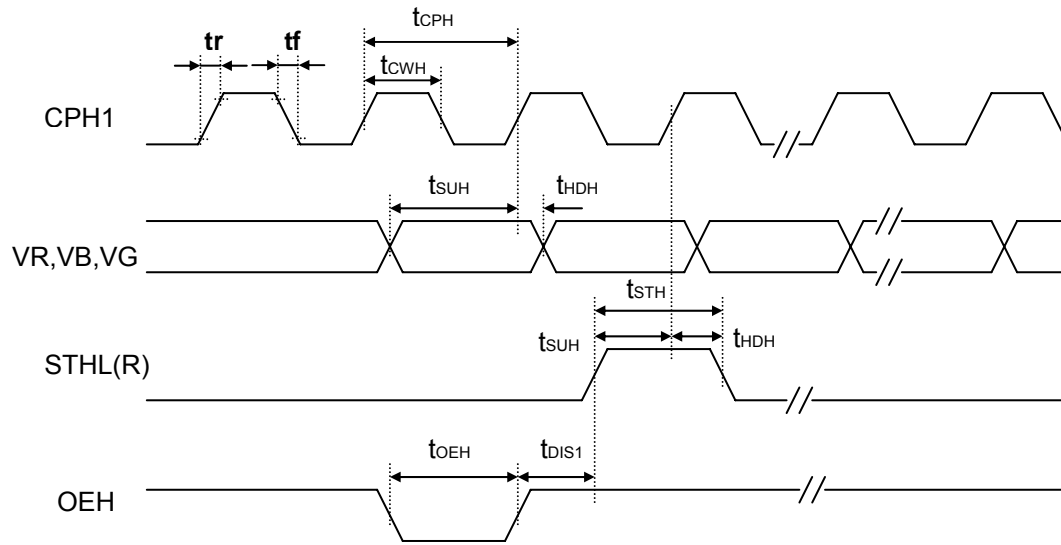

**Sampling clock timing**

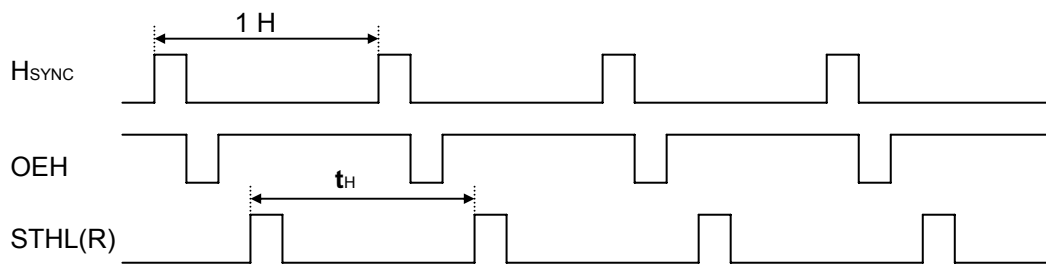
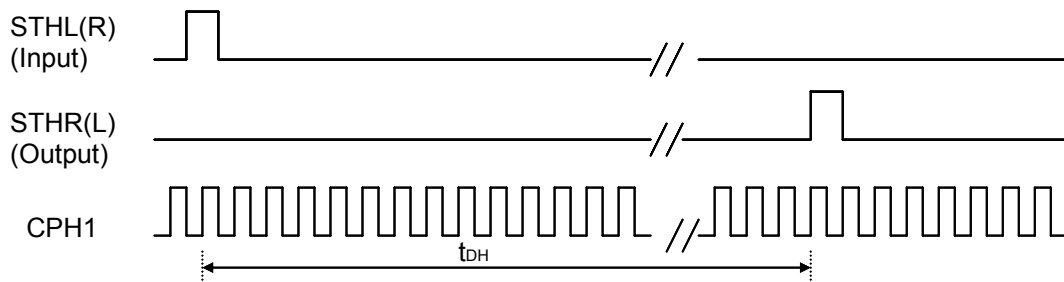

**Horizontal display timing range**



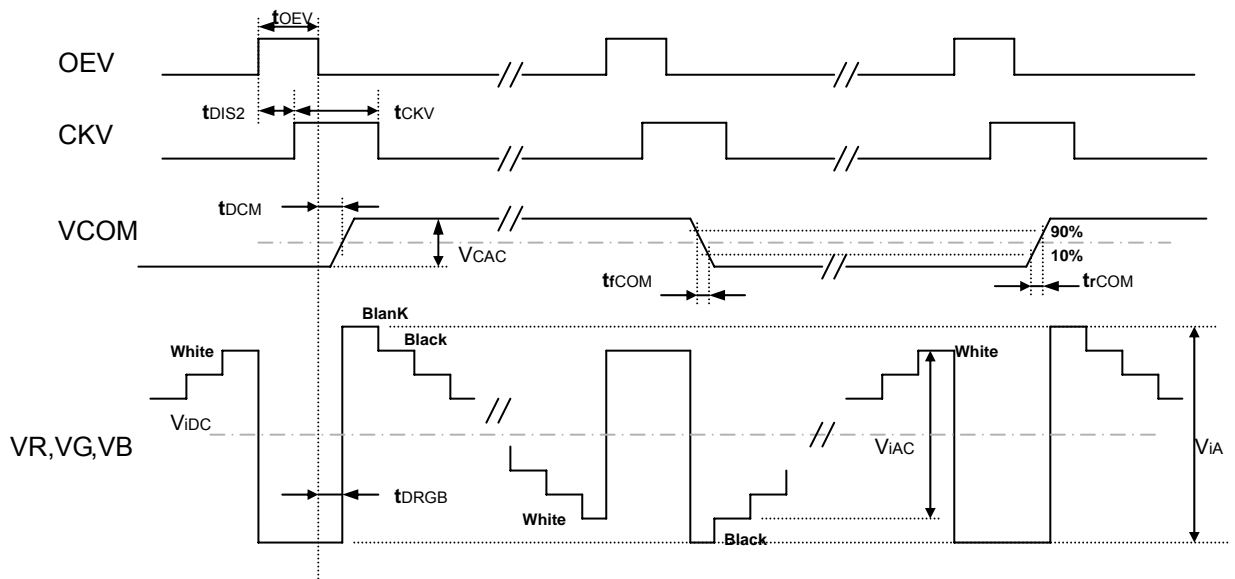

**Detail Horizontal timing**

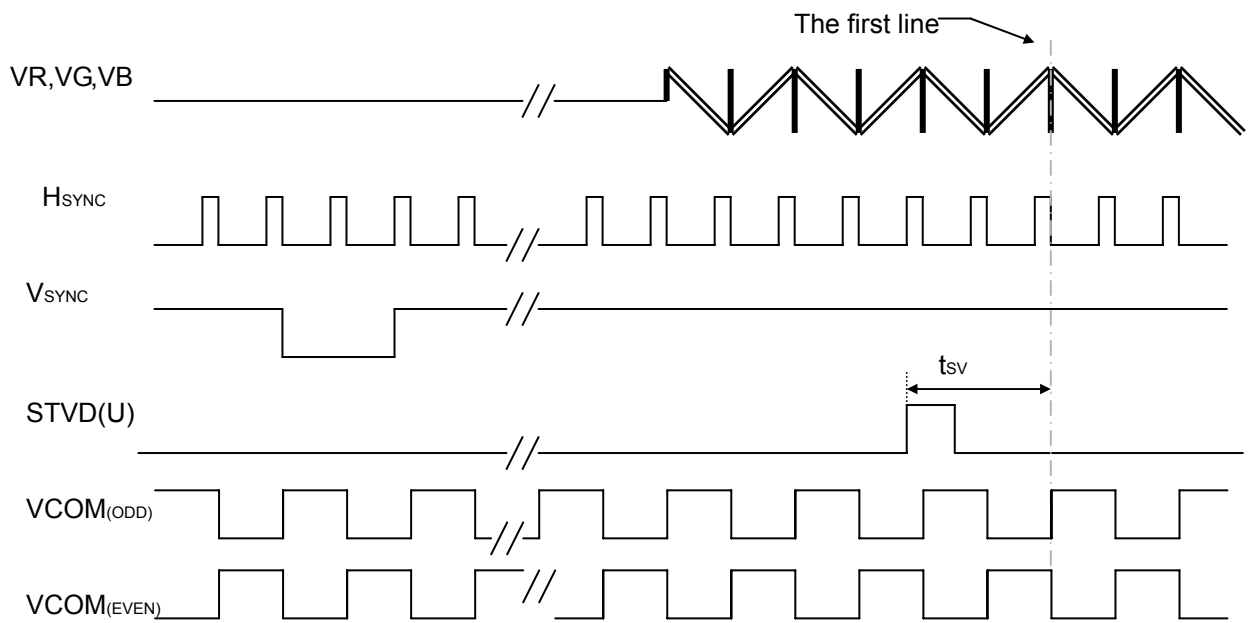

**Vertical timing**

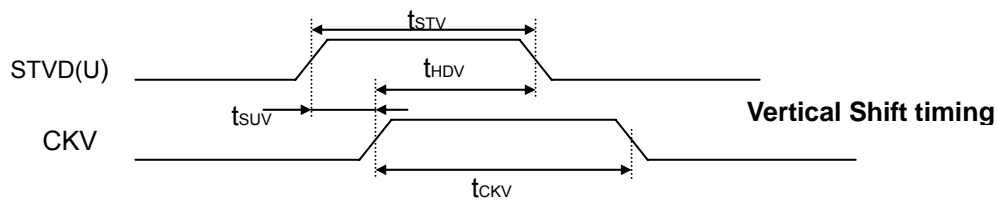

**Vertical Shift timing**

### 6.5 Power Sequence

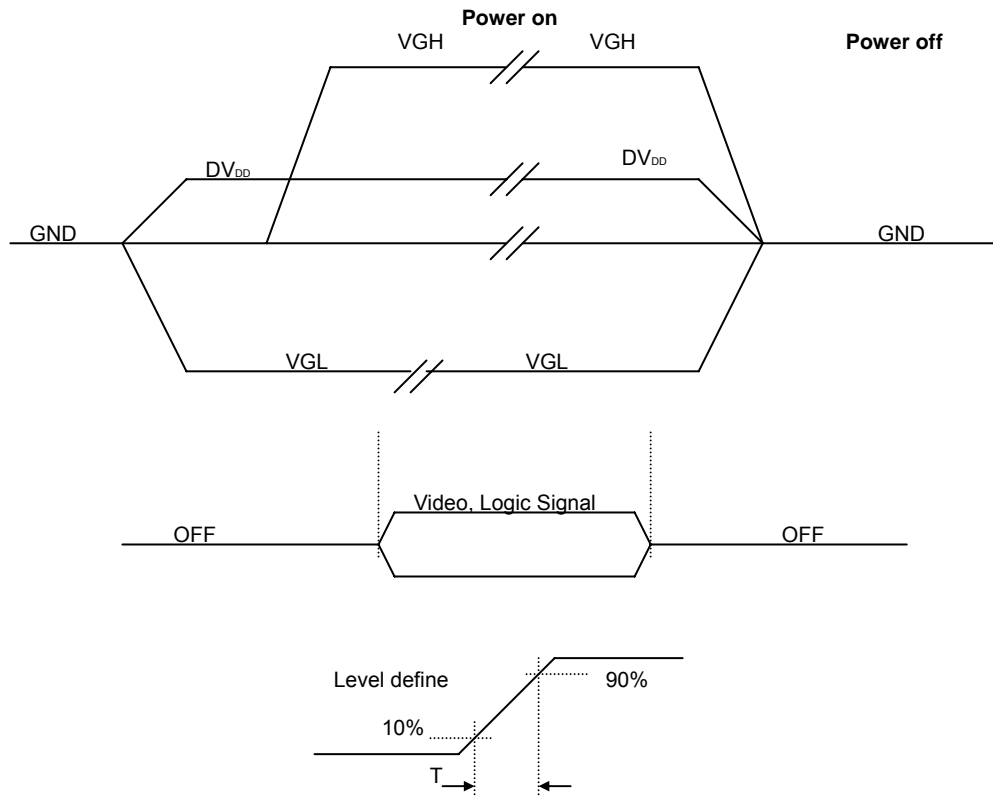

Power Sequence:  $DV_{DD} \rightarrow VGL \rightarrow VGH$

**Note** Apply the lamp voltage within the LCD operation range. When the back-light turns on before the LCD operation or the LCD turns off before the back-light turns off, the display may momentarily become white.



**7.0 OUTLINE DIMENSION**

Unit : mm

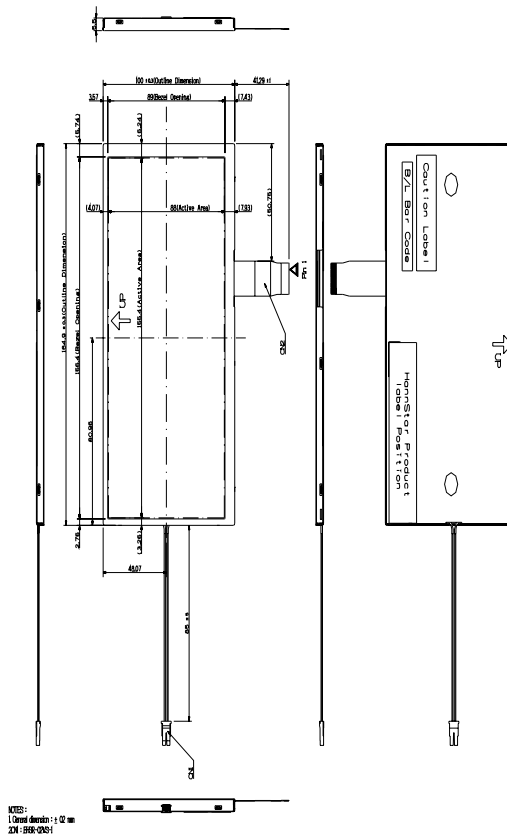



## 8.0 GENERAL PRECAUTION

### 8.1 Use Restriction

This product is not authorized for use in life supporting systems, aircraft navigation control systems, military systems and any other application where performance failure could be life-threatening or otherwise catastrophic.

### 8.2 Disassembling or Modification

Do not disassemble or modify the module. It may damage sensitive parts inside LCD module, and may cause scratches or dust on the display. HannStar does not warrant the module, if customers disassemble or modify the module.

### 8.3 Breakage of LCD Panel

- 8.3.1. If LCD panel is broken and liquid crystal spills out, do not ingest or inhale liquid crystal, and do not contact liquid crystal with skin.
- 8.3.2. If liquid crystal contacts mouth or eyes, rinse out with water immediately.
- 8.3.3. If liquid crystal contacts skin or cloths, wash it off immediately with alcohol and rinse thoroughly with water.
- 8.3.4. Handle carefully with chips of glass that may cause injury, when the glass is broken.

### 8.4 Electric Shock

- 8.4.1. Disconnect power supply before handling LCD module.
- 8.4.2. Do not pull or fold the CCFL cable.
- 8.4.3. Do not touch the parts inside LCD modules and the fluorescent lamp's connector or cables in order to prevent electric shock.

### 8.5 Absolute Maximum Ratings and Power Protection Circuit

- 8.5.1. Do not exceed the absolute maximum rating values, such as the supply voltage variation, input voltage variation, variation in parts' parameters, environmental temperature, etc., otherwise LCD module may be damaged.
- 8.5.2. Please do not leave LCD module in the environment of high humidity and high temperature for a long time.
- 8.5.3. It's recommended to employ protection circuit for power supply.

### 8.6 Operation

- 8.6.1 Do not touch, push or rub the polarizer with anything harder than HB pencil lead.
- 8.6.2 Use fingerstalls of soft gloves in order to keep clean display quality, when persons handle the LCD module for incoming inspection or assembly.
- 8.6.3 When the surface is dusty, please wipe gently with absorbent cotton or other soft material.



- 8.6.4 Wipe off saliva or water drops as soon as possible. If saliva or water drops contact with polarizer for a long time, they may cause deformation or color fading.
- 8.6.5 When cleaning the adhesives, please use absorbent cotton wetted with a little petroleum benzine or other adequate solvent.

### **8.7 Mechanism**

Please mount LCD module by using mounting holes arranged in four corners tightly.

### **8.8 Static Electricity**

- 8.8.1 Protection film must remove very slowly from the surface of LCD module to prevent from electrostatic occurrence.
- 8.8.2 Because LCD module use CMOS-IC on circuit board and TFT-LCD panel, it is very weak to electrostatic discharge. Please be careful with electrostatic discharge. Persons who handle the module should be grounded through adequate methods.

### **8.9 Strong Light Exposure**

The module shall not be exposed under strong light such as direct sunlight. Otherwise, display characteristics may be changed.

### **8.10 Disposal**

When disposing LCD module, obey the local environmental regulations.